

HYDRAULIC
CONTROLS
INC.

5HP Hydraulic Power Unit

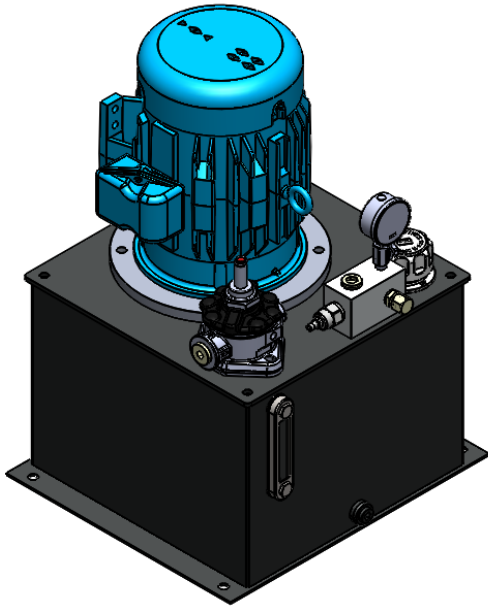

- * 5 GPM @ 1800 RPM
- * 5HP Premium Eff Motor
- * 10 gallon reservoir
- * Rexroth 10u micron filtration
- * Pop-up clogging indicator
- * Optional electrical indicator
- * Oil sight guage
- * Adjustable pressure relief valve
- * Powder coated reservoir

